

dyson airblade tap

Wash and dry
hands at the sink.





“In washrooms using conventional taps, you’ll need to move to a separate hand drying area, dripping water on the floor as you go. It’s why we’ve developed a tap with our hand drying technology in it.”

James Dyson

James Dyson
Inventor

The problems with paper towels

Paper towels are expensive, have a high impact on the environment and cause extra washroom maintenance.

Blockages

Paper towels can clog waste water systems.

Overflowing bins

Soiled towels can end up on the floor of busy washrooms, creating a negative impression of hygiene standards.

Empty dispensers

Dispensers are often left empty leaving no way to dry hands.

Wasteful

Used paper towels are rarely recycled, so they end up in landfill or are incinerated.

Did you know?

Ensuring hands are dry is crucial for maintaining hygiene levels, as damp hands can spread up to 1,000 times more bacteria to the surfaces they touch.



The problems with other hand dryers

Warm air dryers

Warm air dryers are slow. Which means they're energy hungry, expensive to run and unhygienic.

Dry times can take up to 43 seconds, so many users give up before their hands are dry – risking increased spread of bacteria.



Did you know?

Public health specialists NSF state that to be certified as hygienic, a hand dryer must dry hands in 15 seconds or less.

Jet dryers

Other jet dryers might look like a Dyson Airblade™ hand dryer, but when it comes to performance, there's no comparison. Thanks to weak motors, most other jet dryers can't generate the fast airflow needed to dry hands quickly. They can also lack the power required to draw the air through a HEPA filter.

So most other jet dryers aren't just slower than Airblade™ technology, they're less hygienic too.

Have you ever looked inside a drain tank?

Some hand dryers collect waste water using drain tanks. But these are unhygienic – providing the perfect breeding ground for bacteria.

Drain tanks must be emptied and cleaned regularly – adding time and effort to the washroom maintenance process, and risking spillage of waste water during disposal.



Did you know?

In recent testing, Dyson microbiologists detected greater levels of bacteria in a drain tank than levels that can be found in the average household toilet.¹



¹ Sources: Dyson in-house testing, 2015; Scott et al., 2009; Medrano-Felix et al., 2010.

dyson airblade tap

Airblade™ hand drying technology in a tap

With Airblade™ technology in a tap, hands are dried at the sink in 12 seconds. There's no need to move to a separate drying area.

How it works

Both water and air are sensor operated, so there are no taps to turn or buttons to touch. Intelligent infrared sensors emit light to pinpoint hand positions. Computer circuitry coordinates the information and initiates the appropriate response of water or air without long delays.



Airblade™ technology works differently

The Dyson Airblade Tap hand dryer is powered by the Dyson digital motor V4 – one of the world’s smallest, fully-integrated 1600W motors. Its small size and power density are what have made our latest hand dryer technology possible.

Dyson digital motor V4

+ HEPA filter

+ Airblade™ technology

= The fastest over sink hand dryer

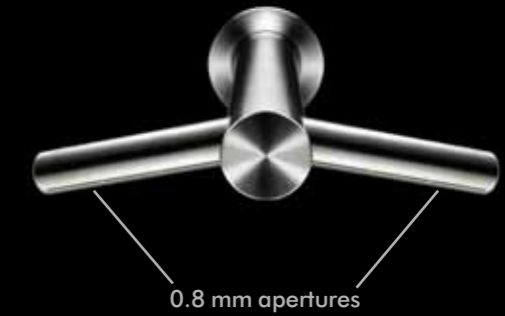

Dyson digital motor V4

Conventional motors are bulky, slow and can be inefficient. They also rely on carbon brushes, which wear out over time. The Dyson digital motor V4 is different. It's one of the world's smallest fully integrated 1600W motors and instead of old-fashioned carbon brushes, it uses digital pulse technology to spin up to three times faster than a conventional motor.

HEPA filter

Bacteria and viruses in washrooms can cause colds, flu, sickness and diarrhoea. Dyson Airblade™ hand dryers have HEPA filters installed as standard, which capture 99.9% of bacteria and viruses in the washroom air. So hands are dried with cleaner air, not dirty air.

Airblade™ technology

Every second, the Dyson digital motor V4 draws in up to 35 litres of air through a HEPA filter, and forces it through apertures just 0.8 mm wide. The result – 430 mph sheets of filtered air that scrape water from hands, drying them quickly and hygienically.

No other hand dryer has this technology

Inside the Dyson Airblade Tap hand dryer





AB09
The Idle Rocks Hotel,
Cornwall, England.

Benefits

- No water on the floor.
- Costs less to run.
- Most hygienic.
- Better for the environment.
- The fastest over sink hand dryer.
- Saves space.
- 5 year guarantee.

Only the Dyson Airblade Tap hand dryer has all of these benefits.

No water on the floor.

Costs less to run.

Most hygienic.

Better for the environment.

The fastest over sink hand dryer.

Saves space.

5 year guarantee.



Water on the floor

When using conventional drying methods, you move to a separate area to dry hands. Water is often dripped on the floor, which can create problems in the washroom. Floor tiles can become slippery, and washroom floors need cleaning more regularly.

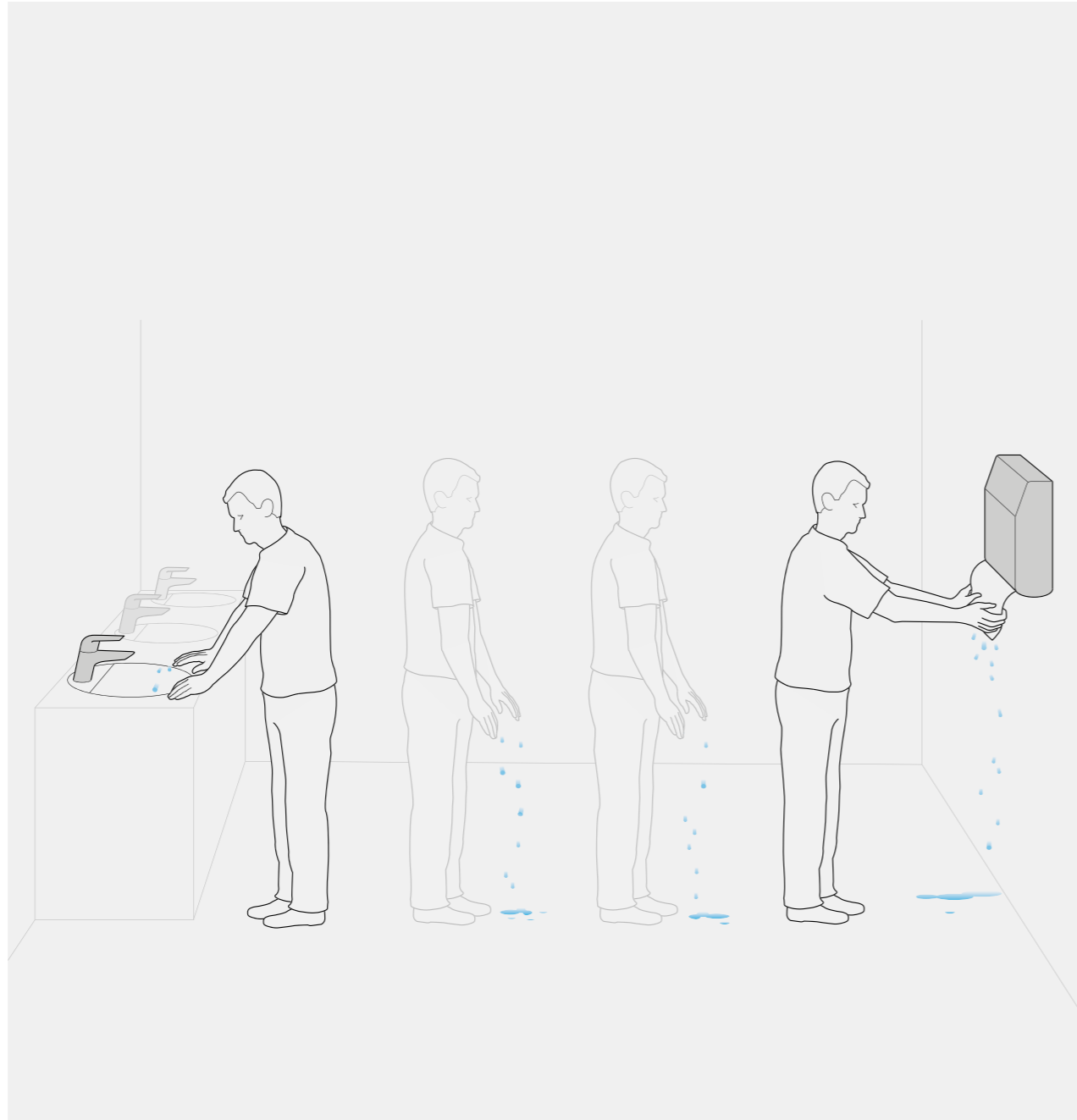

Water in the sink

With the Dyson Airblade Tap hand dryer, water isn't dripped on the floor because you don't need to leave the sink with wet hands.



Hygienic. And costs less to run.

With their slow dry times and lack of HEPA filtration, maintaining a hygienic washroom means avoiding other hand dryers. But as you can see from the graph, paper towels are an expensive alternative.

While paper towels can be just as hygienic as a Dyson Airblade™ hand dryer, their higher fixed running costs add up and up. And up.

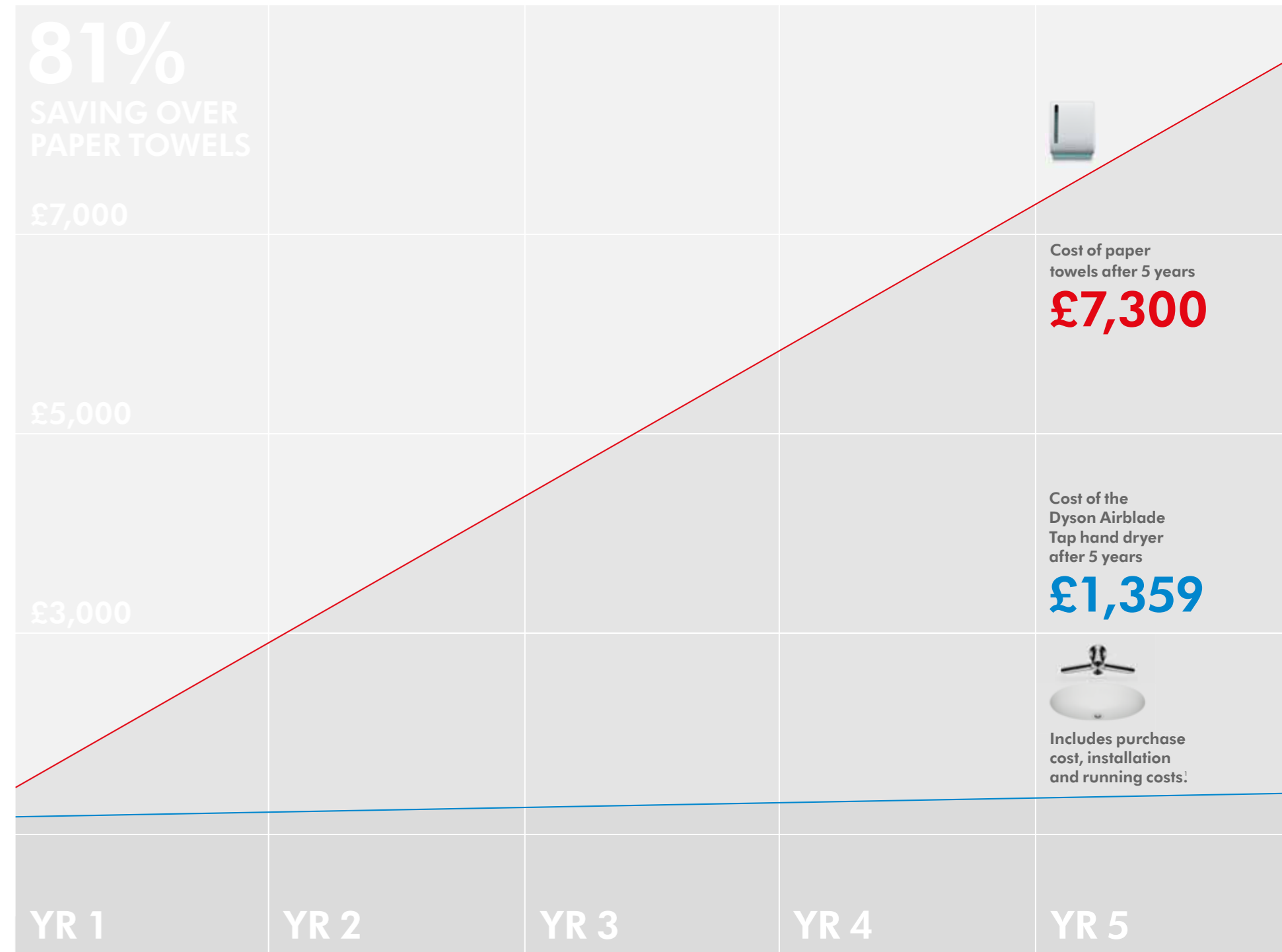

*For calculations visit dysonairblade.co.uk/calcs

Airblade™ technology is fast and the most hygienic

These are the reasons why:

- ↓ Dyson digital motor V4
- + HEPA filter
- + 12 second dry time
- + No drain tank
- + No heating element
- + Touch-free operation

=

The only hand dryer globally accredited by NSF and HACCP International.



Damp hands can spread up to 1,000 times more bacteria than dry hands.

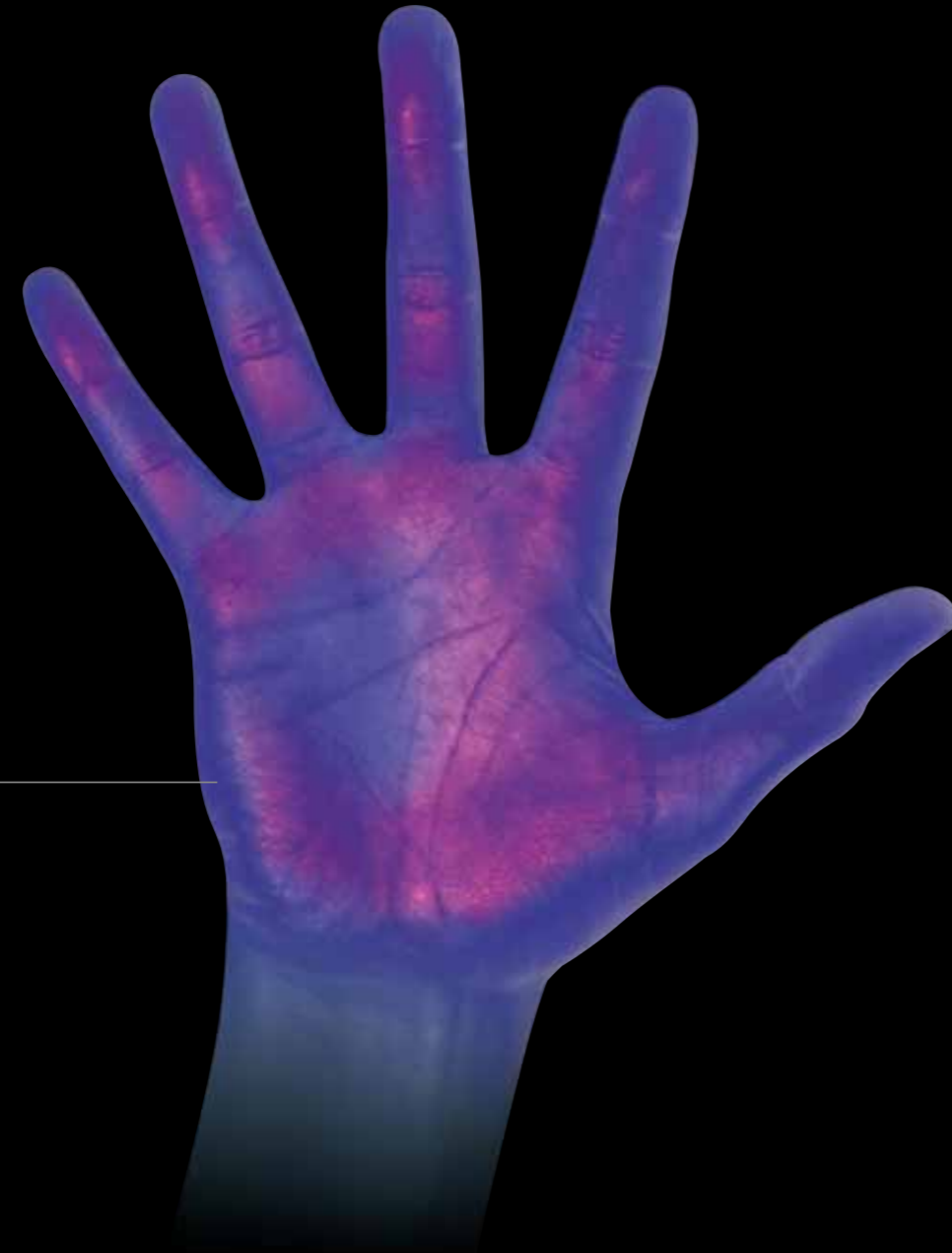

Hygienically drying hands is as important as washing them

Bacteria and viruses deposited by hands onto surfaces can survive for several hours. When others touch these contaminated surfaces, they can be transferred. Damp hands can spread up to 1,000 times more bacteria than dry hands. It's why it's important that hands are dried properly.

The most hygienic hand dryer

The Dyson Airblade Tap hand dryer uses a HEPA filter. 99.9% of bacteria and viruses in the washroom are captured. So hands are dried in 12 seconds using cleaner air, not dirty air.



The environmental impact of paper towels

From cutting down trees, through chemical processes to disposal – using paper towels has a significant impact on the environment.

Felling trees

Trees are a major source of pulp for virgin paper towel production.

Transportation

Once trees are felled they need to be transported from the forest to the mill.

Mix with water

Lots of water and energy are needed to make paper.

Pulping and bleaching

Chemicals are also used in the bleaching process.

Maintenance

Paper towel dispensers need constant restocking.

Disposal

Most used paper towels cannot be recycled. Used paper towels, packaging and bin liners end up in landfill or an incinerator.



High impact on the environment

The Dyson Airblade Tap hand dryer produces 74% less CO₂ than some other hand dryers and 71% less than paper towels.¹



13.9g

CO₂ per dry¹



15.6g

CO₂ per dry¹



8.0g

CO₂ per dry¹

Low impact on the environment

The Dyson Airblade Tap hand dryer has a lower environmental impact across measures including carbon emissions and energy consumption.¹



4.0g

CO₂ per dry¹

¹ In collaboration with Carbon Trust, Dyson has produced a method to measure the environmental impact of electrical appliances and paper towels. The carbon calculations were produced using GaBi software provided by PE International, based on product use over 5 years and using the US as a representative country of use. Dry times for products were evaluated using DTM 769.

Other hand dryers are too slow

Testing based on NSF Protocol P335 shows that most other hand dryers are much slower than their manufacturers claim – with dry times based on drying hands without a HEPA filter. Many people give up when using a slow hand dryer. But damp hands can spread up to 1,000 times more bacteria than dry hands.



43 sec

22 sec

No HEPA filter as standard



Dyson hand dryers are fast

Testing based on NSF Protocol P335 shows that the Dyson Airblade Tap hand dryer is fast. Every second, up to 35 litres of air is forced through apertures measuring just 0.8 mm wide. The result – 430 mph sheets of air that scrape water from hands, drying them quickly and hygienically.



12 sec

HEPA filter as standard

NSF Protocol P335

For a more detailed overview of NSF Protocol P335 please see the reference section at the end of the brochure.



AB09

The Coca Cola London Eye, tourist attraction, UK.

“As an iconic global landmark, The London Eye needs to meet high expectations of quality – and that extends to our washrooms. Installing the Dyson Airblade Tap hand dryer has allowed us to achieve this.”

Davey Barrett,
Services Manager.

Separate hand washing and drying areas need more space

Paper towel dispensers and hand dryers take up valuable wall and floor space in public washrooms.



The Dyson Airblade Tap hand dryer saves space

With no need for additional hand drying areas, there's room for extra cubicles. Or the washroom can be made smaller.



5 year guarantee. Unrivalled service.

Dyson Airblade™ hand dryers are engineered to last. They have been repeatedly tested for durability and resilience to physical abuse. They have also been exposed to real-life environments to ensure that they can withstand the pressures of high usage.

Guarantee

Thanks to this rigorous testing regime, all factory parts on Dyson Airblade™ hand dryers are guaranteed against original defects in materials and workmanship for 5 years.

Aftersales support

If anything does go wrong with your machine, we provide repair and maintenance support through Dyson service engineers and self-service spare parts. Reducing downtime and disruption to your facilities.

Dyson Airblade Tap hand dryer
5 year parts and labour.

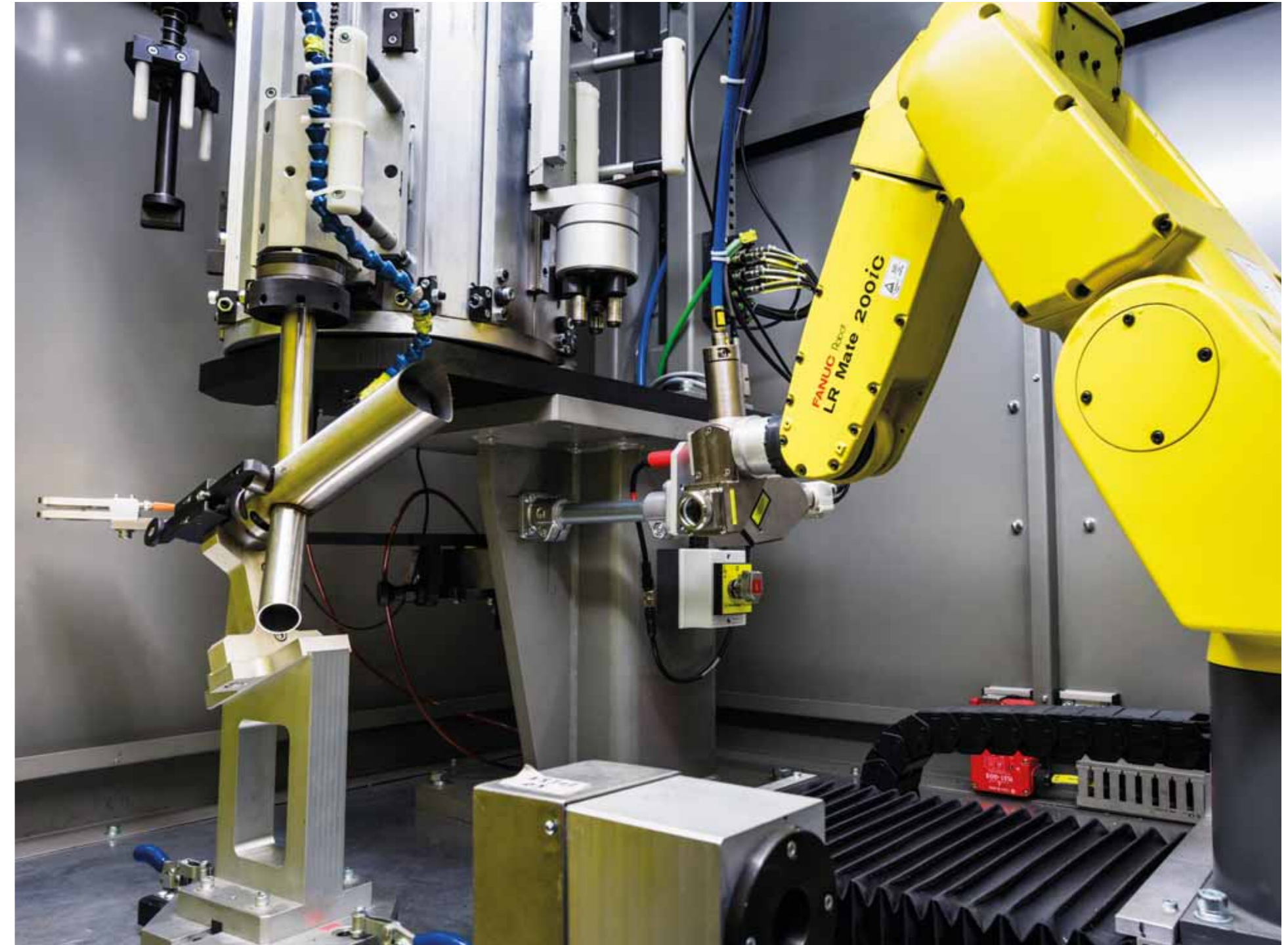



AB09
Pathé cinema,
Holland.

Accreditations

Certified by the Carbon Trust.

Certified by HACCP International.

Certified by NSF.

The only hand dryer certified by the Carbon Trust

Everything we make or use has a carbon footprint. It represents the total amount of carbon dioxide and other greenhouse gases generated during its life.

Working with the Carbon Trust, Dyson has measured the carbon footprint of the Dyson Airblade™ hand dryer range.

Every single component

All components inside the Dyson Airblade™ hand dryer were assessed. Materials and manufacture contribute 8% of total emissions.

Waterways vs. highways

Constant paper towel restocking relies on road transport. Dyson Airblade™ hand dryers use energy-efficient ships – representing less than 1% of total emissions.

Less energy = less carbon

Airblade™ technology has fast dry times and no energy-hungry heating elements. So it uses up to 80% less energy than warm air dryers.

End of life

With a 5 year guarantee, the Dyson Airblade™ hand dryer is built to last. Even so, many components are designed to be recyclable with negligible environmental impact.



Certified by HACCP international.
Safe for the food sector.

The Dyson Airblade Tap hand dryer has been certified for use in food preparation environments by HACCP International. The Dyson Airblade Tap hand dryer and the Dyson Airblade dB hand dryer are the only hand dryers globally certified for use in the food and beverage industry.



AB11
Merba,
food production,
Holland.

The only hand dryer certified hygienic

NSF certified

Dyson asked independent public health specialists NSF to define the criteria for a hygienic hand dryer. The result is NSF Protocol P335 – and Dyson Airblade™ hand dryers are the only hand dryers that meet every part of it.

Air filtration

Air used to dry hands must be HEPA filtered.

Unheated air

Warming moist bacteria increases their reproduction rate. Heated air can also remove beneficial oils from the skin.

Drying time

Hands must be dried in under 15 seconds. NSF have defined dry as 0.1g of residual moisture. Damp hands can spread up to 1,000 times more bacteria.







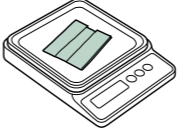
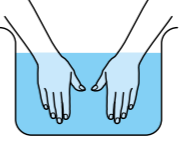

Touch-free operation

The hand dryer must start and stop without user contact.

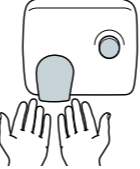
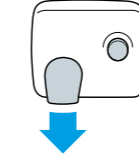

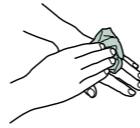
TESTED. CERTIFIED. HYGIENIC

When are dry hands dry? Here's how they test it.

<p>1</p> 	<p>2</p> 	<p>3</p> 	<p>4</p> 
<p>Take three male and female volunteers.</p>	<p>Fold paper towel once, place on digital scales and record weight.</p>	<p>Place both hands in water container up to level of wrist crease for five seconds. Rub hands in the water to remove trapped air and bubbles.</p>	<p>Remove hands from container and let water drip from hands for five seconds.</p>
<p>5</p> 	<p>6</p> 	<p>7</p> 	<p>8</p> 
<p>Place hands under dryer 5 cm from outlet. Dry hands according to manufacturer's instructions. If these instructions include rubbing then rub hands at a rate of two times per five seconds.</p>	<p>Once air begins to flow from dryer start to rub and dry hands. Commence drying process by rubbing palms together twice.</p>	<p>Continue drying process by rolling hands twice.</p>	<p>Continue drying process by interlocking and unlocking hands twice.</p>
<p>9</p> 	<p>10</p> 	<p>11</p> 	 <p><0.1g <input checked="" type="checkbox"/> >0.1g <input type="checkbox"/></p>
<p>Remove excess water from hands (between fingers and wrist) with paper towel until hands feel dry. Roll towel into a ball and place on scales within five seconds.</p>	<p>Re-weigh the towel and record the weight.</p>	<p>Repeat the test for all six volunteers and calculate the mean dry time of the six tests.</p>	<p>The machine will be considered 'hygienic' only if the unit can effectively dry hands to less than 0.1g of residual moisture within 15 seconds. Anything over 0.1g of moisture means the product will be deemed unhygienic.</p>



AB10
Van der Valk Hotel,
Holland.

Technical overview

[AB09 technical overview.](#)

[AB10 technical overview.](#)

[AB11 technical overview.](#)

dyson airblade tap

Visit website for full downloadable technical specifications, sink recommendations and pre installation guides.
www.dysonairblade.co.uk

Tap dimensions

AB09 Height 159 mm Width 297 mm Depth 286 mm

Motor bucket dimensions

AB09 Height 266 mm Width 142 mm Depth 189 mm

Minimum clearance

Z 100 mm clearance from floor.

Motor bucket must be installed below the sink, upright or on its side.



REAR ELEVATION

SIDE ELEVATION

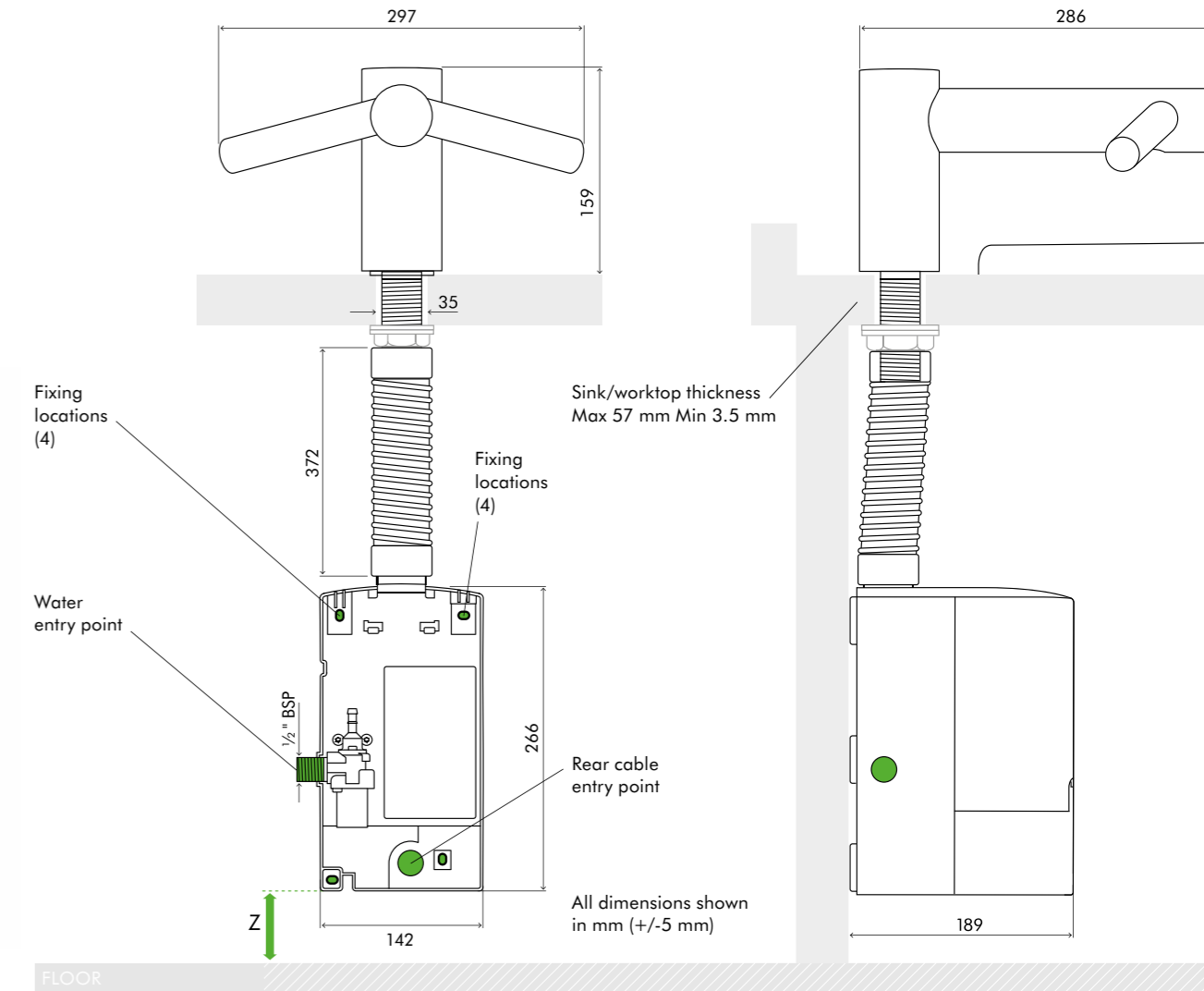

dyson airblade tap

AB
TO Long

Visit website for full downloadable technical specifications, sink recommendations and pre installation guides.
www.dysonairblade.co.uk

Tap dimensions

AB10 Height 309 mm Width 297 mm Depth 286 mm

Motor bucket dimensions

AB10 Height 266 mm Width 142 mm Depth 189 mm

Minimum clearance

Z 100 mm clearance from floor.

Motor bucket must be installed below the sink, upright or on its side.



REAR ELEVATION

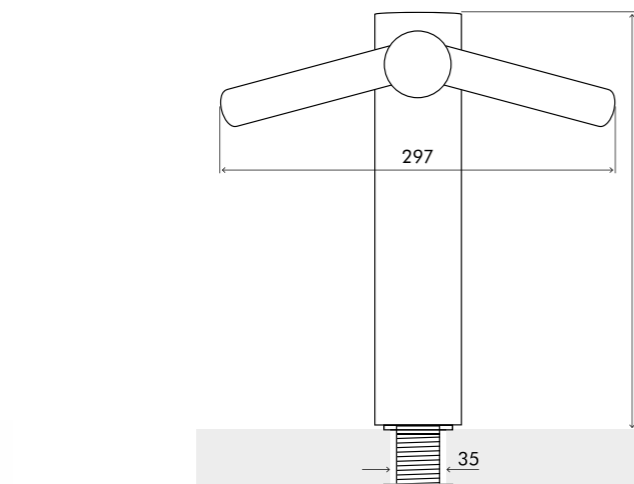

Fixing locations (4)

Water entry point

Z

142

372

35

297

309

Fixing locations (4)

Sink/worktop thickness
Max 57 Min 3.5

Rear cable entry point

266

All dimensions shown in mm (+/-5 mm)

SIDE ELEVATION

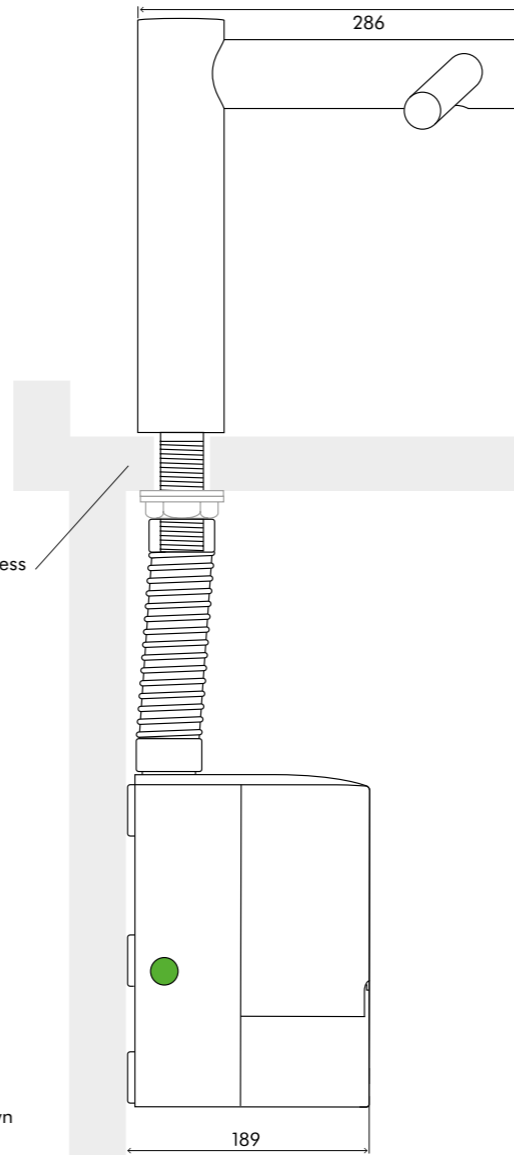

286

189

AB
11 Wall

dyson airblade tap

Visit website for full downloadable technical specifications, sink recommendations and pre installation guides.
www.dysonairblade.co.uk

Tap dimensions

AB11 Length 312 mm Width 297 mm

Motor bucket dimensions

AB11 Height 266 mm Width 142 mm Depth 189 mm

Minimum clearance

Z 100 mm clearance from floor.

The AB11 Wall Tap is designed so the motor unit is located behind the stud wall. It is supplied with a metal enclosure which needs to be assembled into the stud work behind the wall.



SIDE ELEVATION

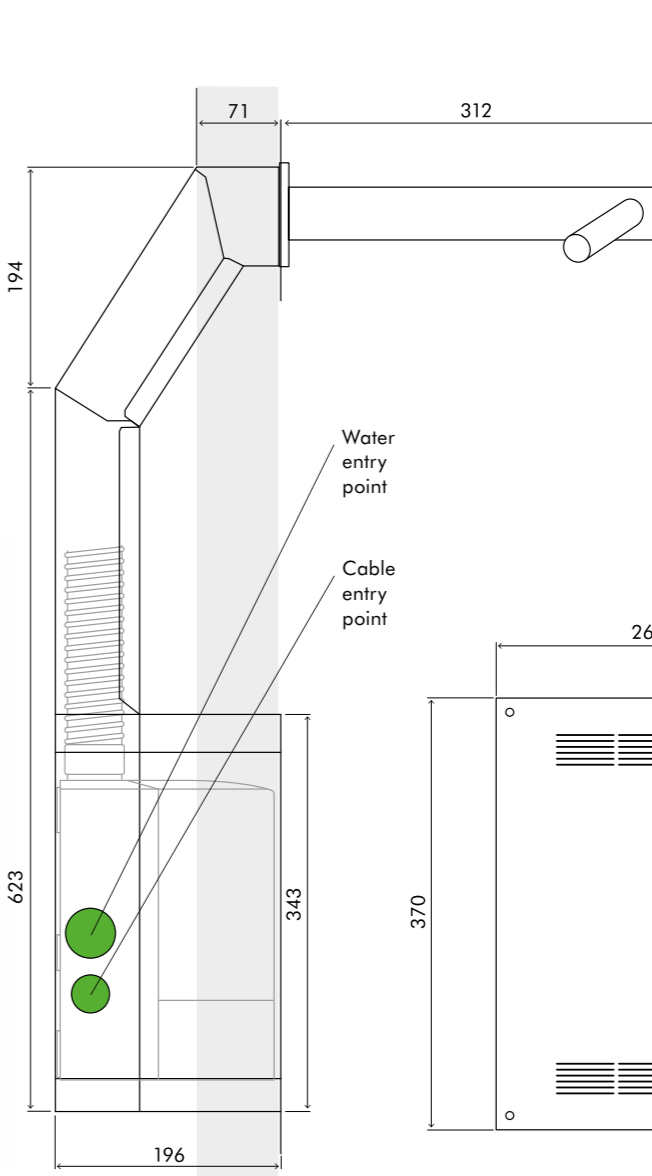

71

312

194

623

Water entry point

Cable entry point

343

370

260

196

FLOOR

REAR ELEVATION

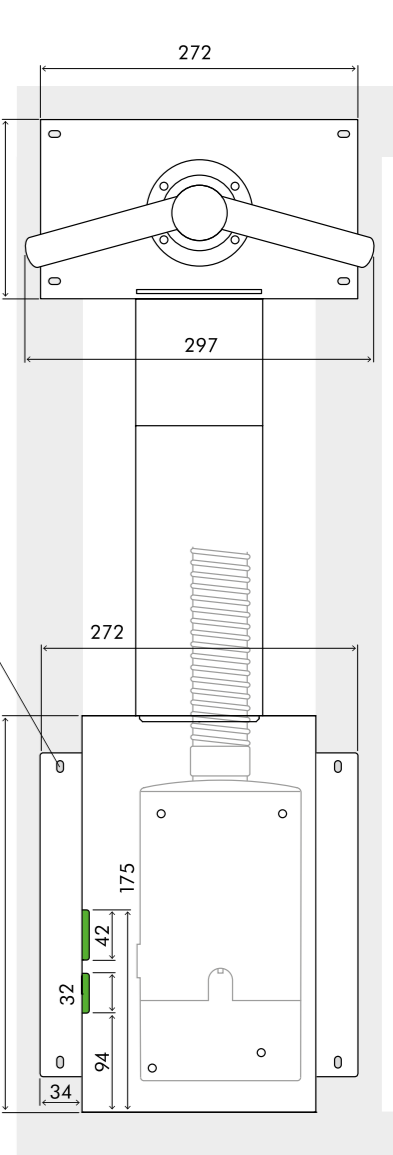

272

153

297

272

342

175

42

94

34

FLOOR



AB10
Broad Oak Mini,
car dealership,
UK.

Pre installation

[Points to consider before installation.](#)

[Sink compatibility guide.](#)

[AB09 pre installation overview.](#)

[AB10 pre installation overview.](#)

[AB11 pre installation overview.](#)

Points to consider before installation.

Environment

Indoors only.

Dry environment.

Below 2000 metres.

Electrical supply

Dedicated 15 amp power supply per appliance.

Correct power available to the appliance
(HV 200-253 V 1600 watt/LV 110-127 V 1400 watt).
Isolated by switch fuse spur.

Water supply

Water pressure between 1-8 bar.

1x 1/2" BSP pipe feed required.

Water temperature controller required
(thermostatic mixer/water heater).

Water isolation valve required
for ease of install/service.

Location of motor bucket

AB09 / AB10 – Room under sink for motor to be
mounted to surface (266 mm x 142 mm x 189 mm).

Allow for a minimum of 100 mm distance
between the floor and the motor bucket.

AB11 – Metal enclosure (supplied with appliance)
to be fitted behind wall (minimum depth 200 mm).

Sink compatibility

A wide range of sink styles have been tested and approved for use with the Dyson Airblade Tap hand dryer. Here is a small selection.

For the full list of compatible sinks visit www.dyson.co.uk/airblade/useful-documents

If a specific sink is not listed we can help with advice on the suitability.

Counter top sinks



Recessed



Pedestal mounted



Wall mounted



Under counter



Pre installation overview

Sink specification guidelines

Using a specially designed test method, Dyson engineers tested a wide range of sinks to assess their compatibility with the Dyson Airblade Tap hand dryer. For recommended sinks, please use our guide at www.dyson.co.uk/airblade/useful-documents

Porcelain or brushed metal sinks are ideal.

Sinks with highly polished surfaces should be avoided e.g. reflective chrome.

Tap mounting

The tap stem (measured from the outside diameter) should be mounted 15-40 mm from the outside edge of the sink.

There should be a minimum of 290 mm between a tap centre and a side wall. When multiple taps are installed side-by-side, tap centres should be a minimum of 580 mm apart. This allows sufficient space for mounting the motor bucket, as well as sufficient shoulder room for users.

Do not place the downward facing water sensor of the tap over a reflective surface, such as the drainage hole (Fig.4).

Visit website for full downloadable pre installation guides for AB09, AB10 and AB11.

www.dysonairblade.co.uk

Soap and locating the soap dispenser

For the best user experience, Dyson recommends the use of gel soaps.

The infrared sensing zone for air activation extends along each tap branch. In order to prevent accidental activation, it's important to consider the user's hand route to the soap dispenser.

The dispenser should be located at least 60 mm outside the width of the tap, so the user reaches around the side of the branch.

It should also be located at least 60 mm above the branches, so that the sensors are not activated.

Please note that the user may reach diagonally across for the soap, so this path must not go through the sensing zone.

Fig.1

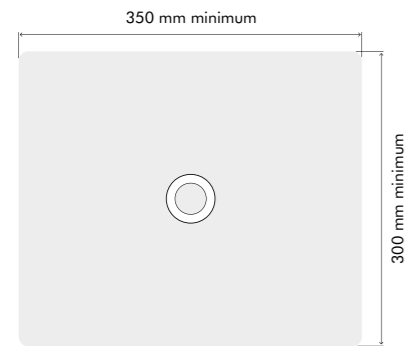

Fig.2

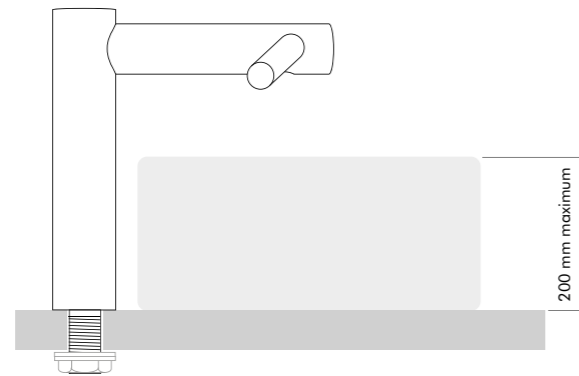

Fig.3

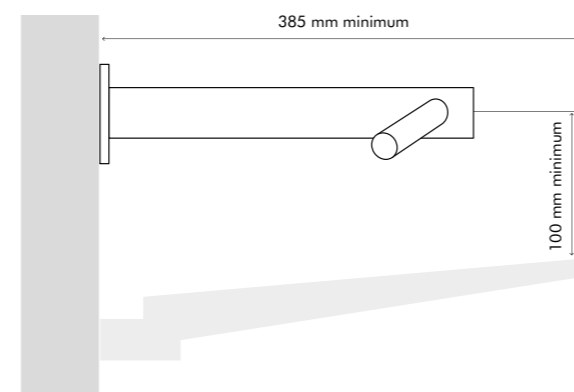
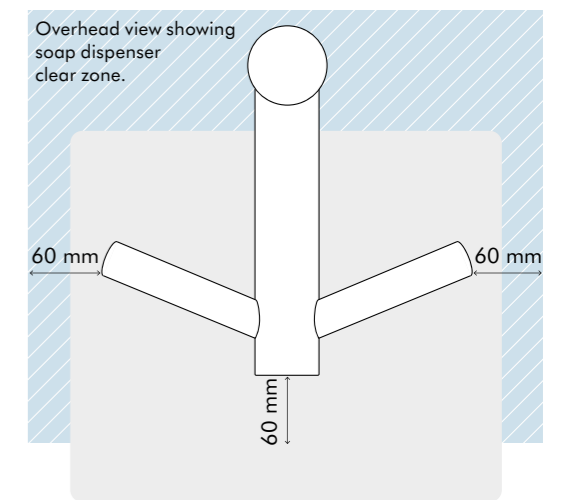
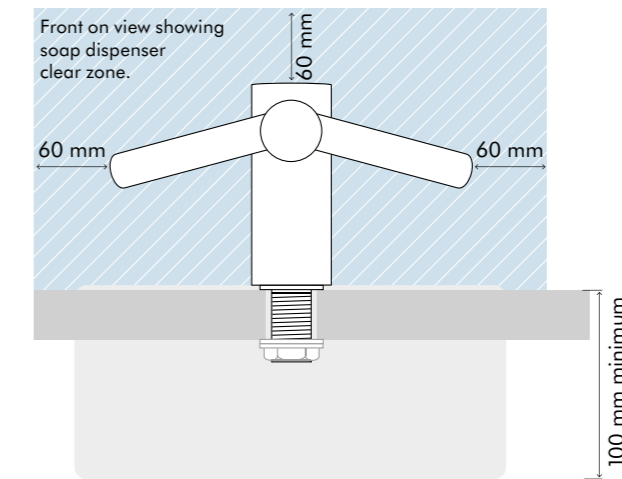
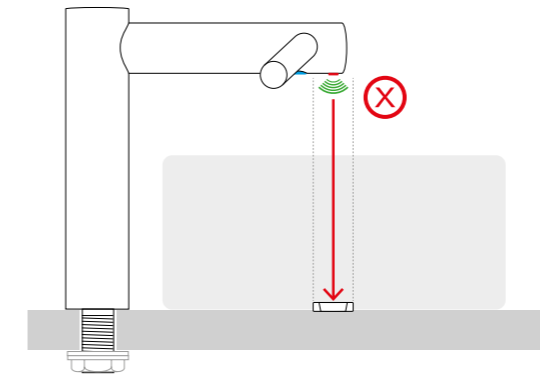

Fig.4



Sink dimensions

(All internal measurements unless otherwise stated)

Fig.1 Width of sink minimum: 350 mm.
Front to back of sink minimum: 300 mm.

Fig.2 Maximum depth of sink for Long Neck Tap (AB10) only: 200 mm
(External measurement of vessel/pedestal sink).

Fig.3 Minimum distance from tap centre to top of sink (AB11 only) 100 mm. Front edge of sink (all types – pedestal, recessed, slab) to wall minimum 385 mm.

Fig.4 Do not place the downward facing water sensor of the tap over a reflective surface, such as the drainage hole.

Water drainage

Due to high velocity air and water being in close proximity, there is a chance of some water and soap dispersion outside the sink dimensions. To alleviate this effect, we recommend following the below guidelines.

Base profile

Flat base profile will result in poor drainage leading to high levels of splashback.

Base to back and front wall transition

The base to back and front wall transition should also be considered. The back wall should be as close to 90°, and at as sharp a radius as possible (Fig.7). Curved geometry is more likely to increase splashback, whereas sloping back and front wall transitions should be avoided (Fig.8 & 9).

Sink access guidelines

It is recommended that the guidelines below are followed to ensure there is sufficient access under the sink to allow for servicing and installation to take place (Fig.10).

Fig.5

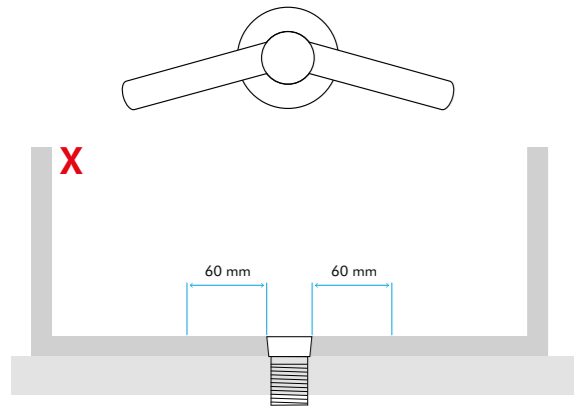

Fig.5 To improve drainage, avoid sinks with a flat base with particular focus on the immediate area surrounding the drain hole, minimum 60 mm radius.

Fig.6

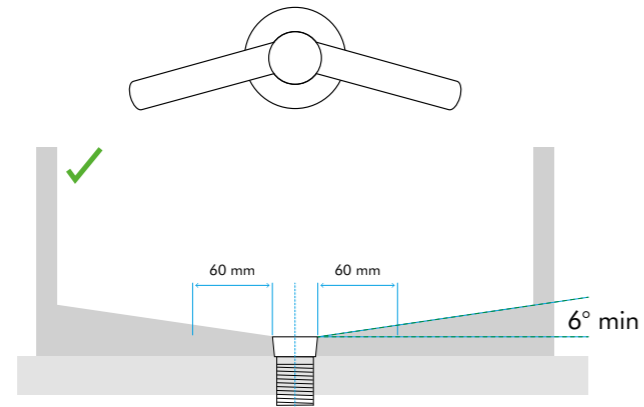

Fig.6 Minimum of 6° ramp angle from the edge of the drain hole of the sink will result in good drainage leading to reduced levels of splashback (minimum 60 mm radius).

Fig.7

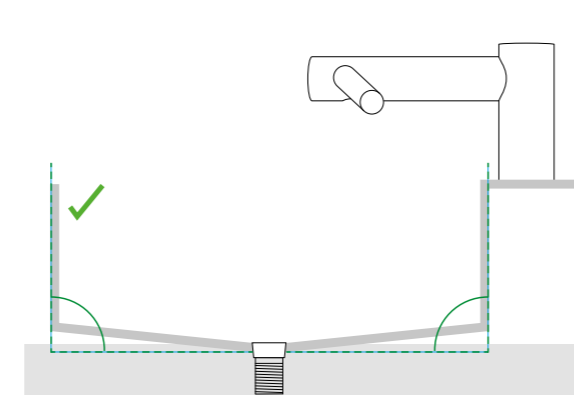

Fig.7 Vertical and sharp transition.

Fig.8

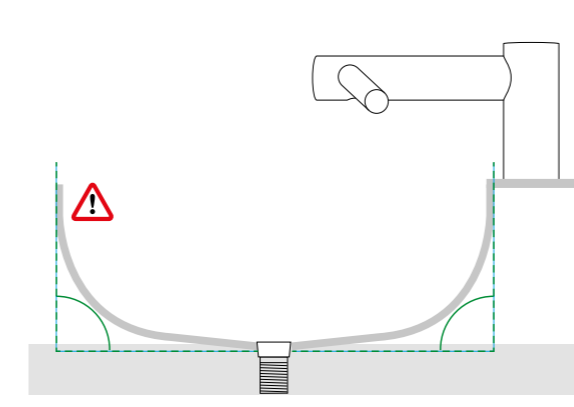

Fig.8 Vertical and smooth transition.

Fig.9

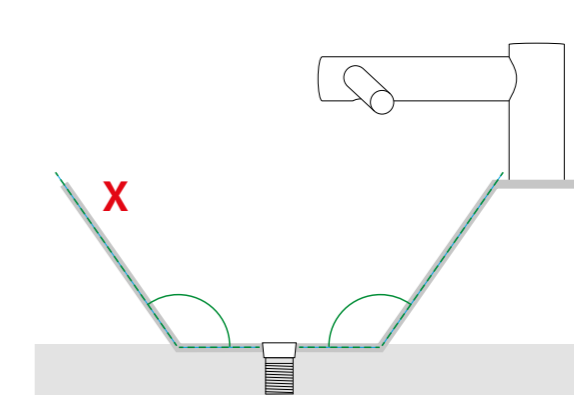

Fig.9 Sloped transition.

Fig.10

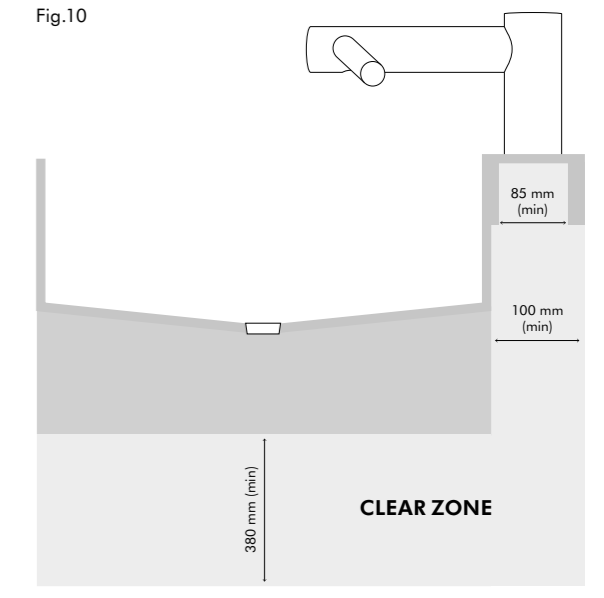

Fig.10 380 mm minimum access below sink.

Plug hole

Plug holes with the most open aperture are recommended, whereas grill or perforated type plug holes should be avoided as they restrict the drainage of soapy water (lather). Do not use plugs in the plug holes in the sinks.

Mounting the motor bucket (AB09/AB10)

Ensure 100 mm minimum clearance from bottom of motor bucket to floor/wall.

The motor bucket cannot be mounted upside down or installed above the sink.

Only the following is advised (Fig.11).

Installing AB11

The AB11 Dyson Airblade Tap hand dryer is designed so that the motor unit is located behind a stud wall within a metal enclosure which is supplied with the Dyson Airblade Tap hand dryer (Fig.12). The vertical wall studs must be constructed so as to allow the metal enclosure to be fitted between them (Fig.13). One of the horizontal wall studs must be fitted a) so it holds the main weight of the metal duct and the unit, and b) so it is in the correct position for the tap stem.

For complete instructions, please refer to the printed installation guide supplied with the machine. It's also available online at www.airblade.co.uk

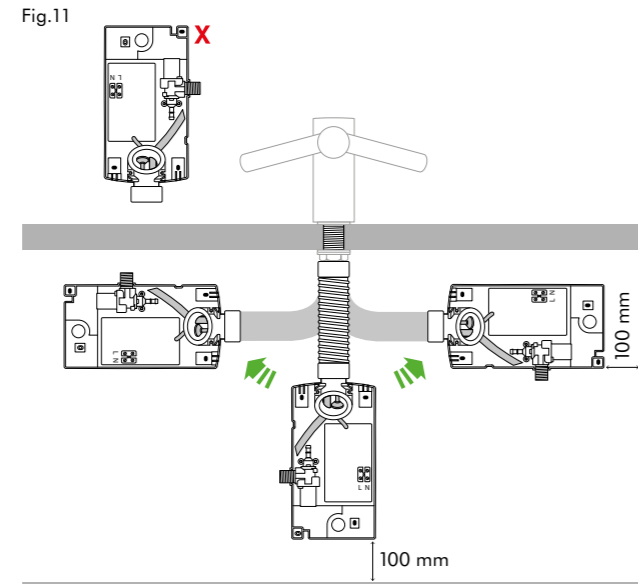
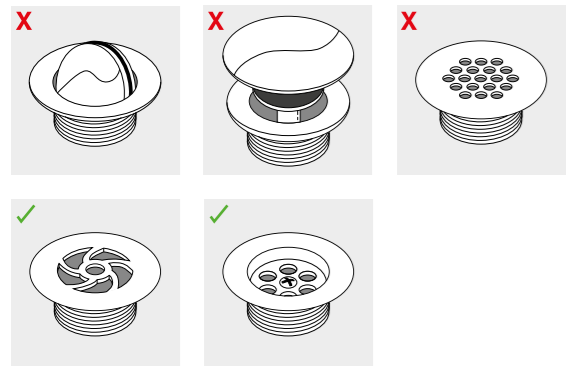

Fig.11 Only the following is advised.



Fig.12 AB11 metal enclosure assembly.

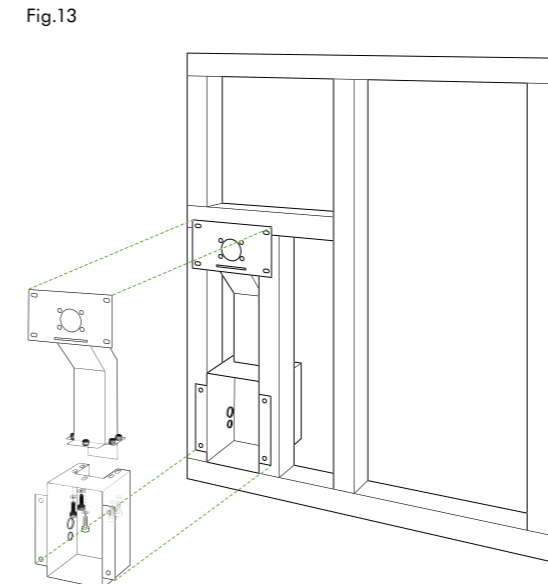

Fig.13

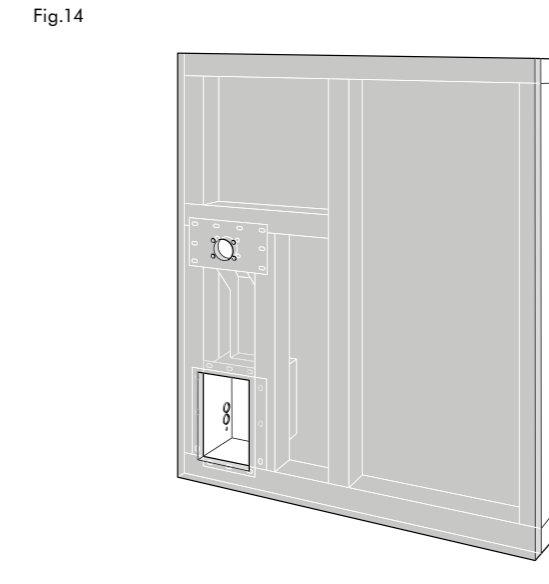

Fig.14

Fig.14 Install plasterboard.

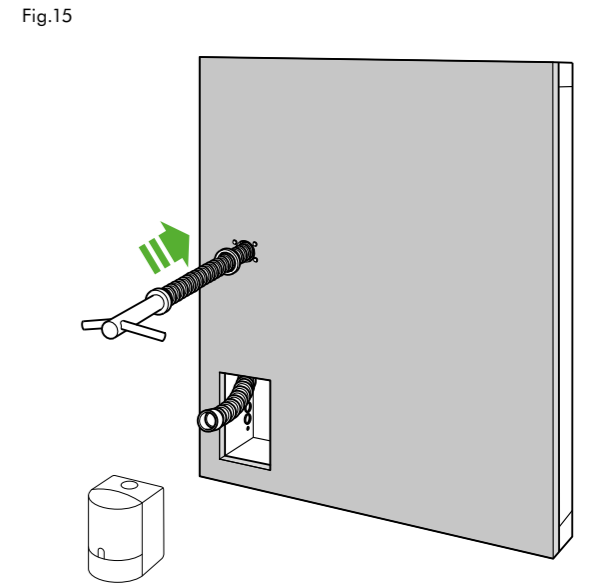

Fig.15

Fig.15 Install Dyson Airblade Tap hand dryer.

Water temperature control

If you are connecting a hot and cold water feed, you will need to install a thermostatic mixer (Fig 16, not supplied).

If you are connecting to cold only water feed, you will need to install a heater (Fig 17, not supplied).

Fig.16

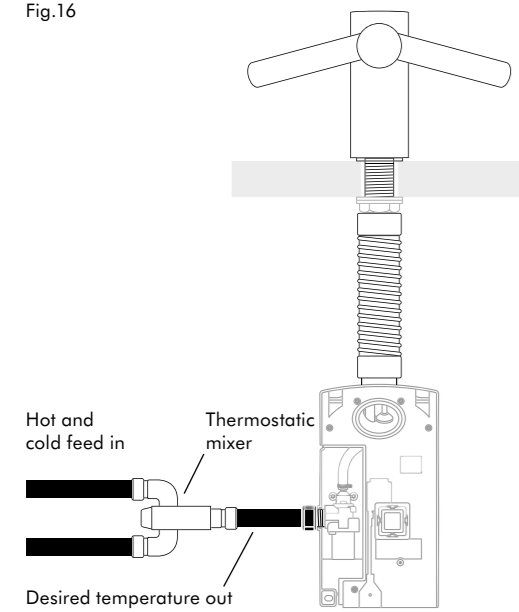
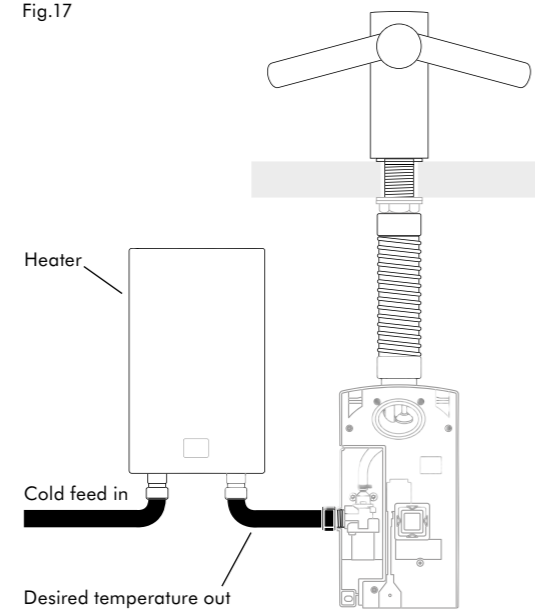

Fig.17



[AB09 AB10 installation overview](#)

[AB11 installation overview](#)

AB
09 Short

AB
10 Long

Installation overview

Visit website for full downloadable installation guide.
www.dysonairblade.co.uk

What's in the box

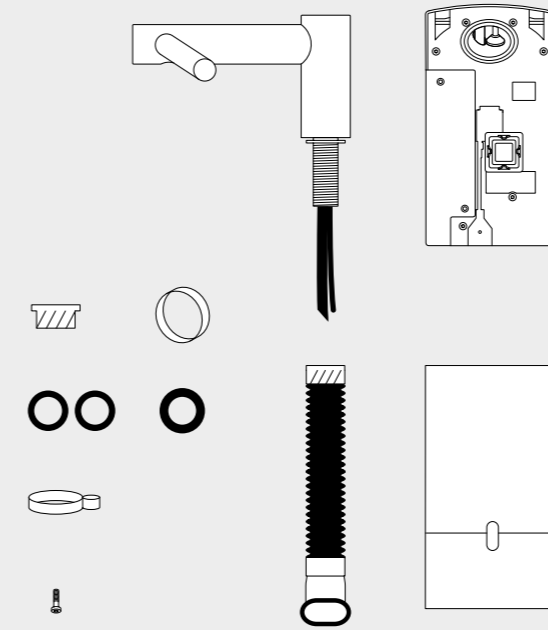

Additional items you will need for installation

Torx T15 screw driver – long handle

37 mm Box spanner

Mains power supply

Water temperature control: Thermostatic mixer or heater

Water pressure control if pressure is not between 1 and 8 bar

1

Assemble

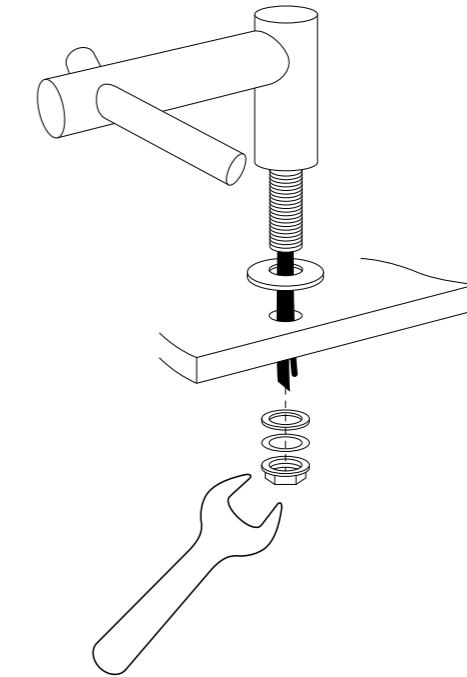

2

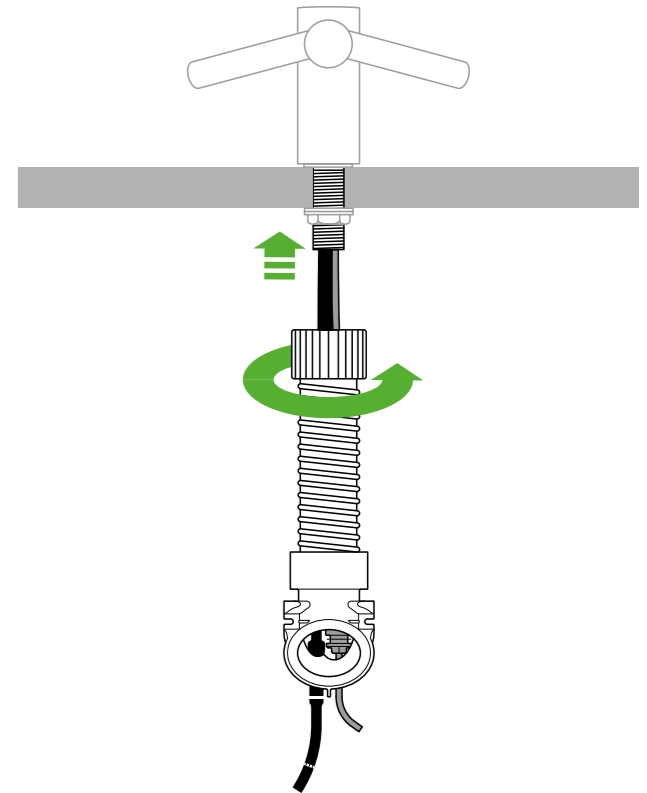

Installation overview

3

Decide motor location

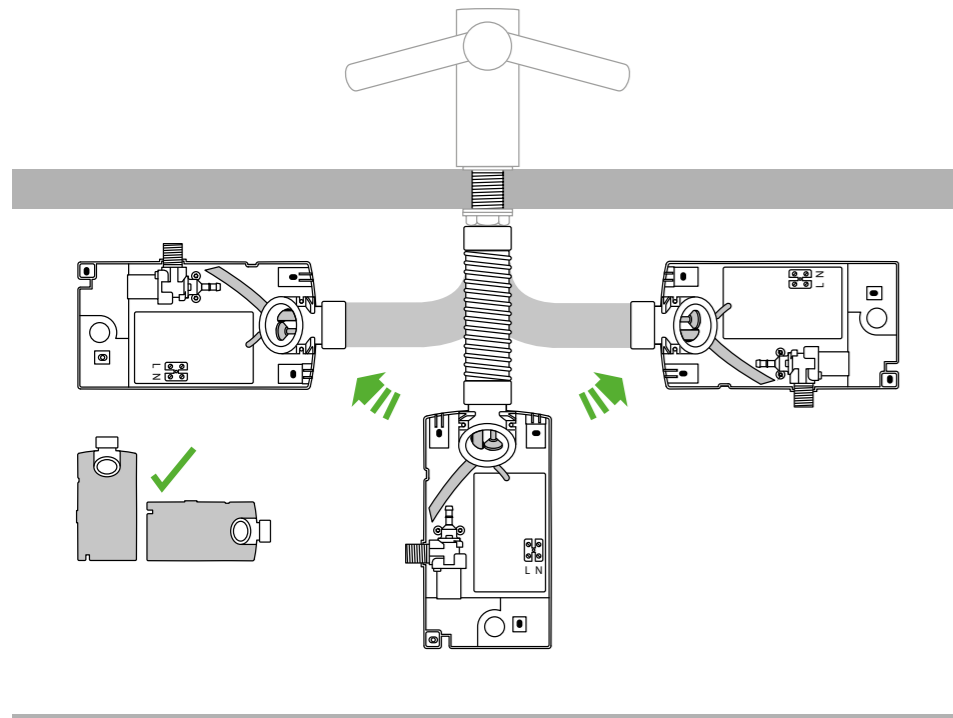

4

Connect supplies
Electrics

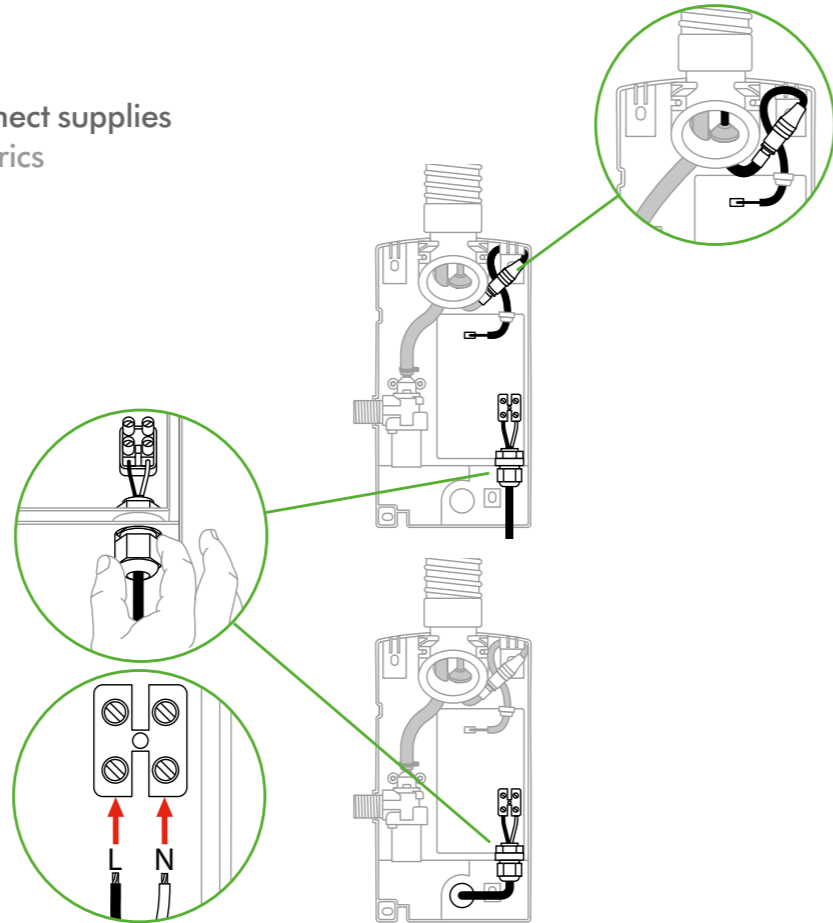

Connect supplies
Water

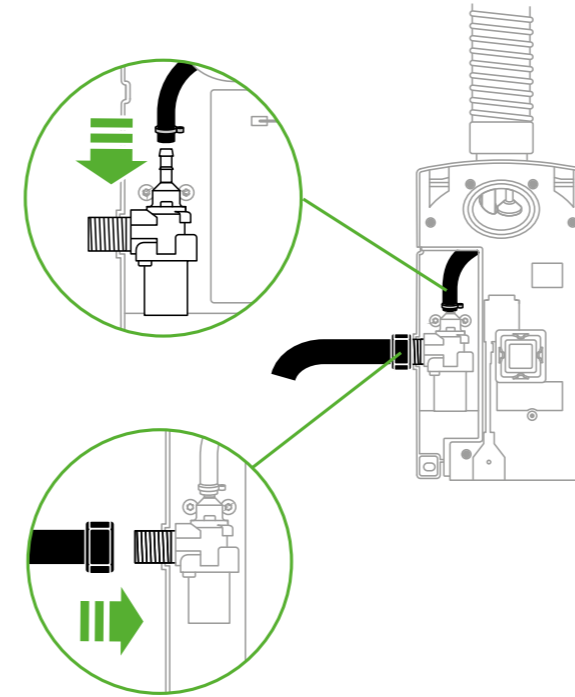

If you are connecting a hot and cold water feed, you will need to install a thermostatic mixer.

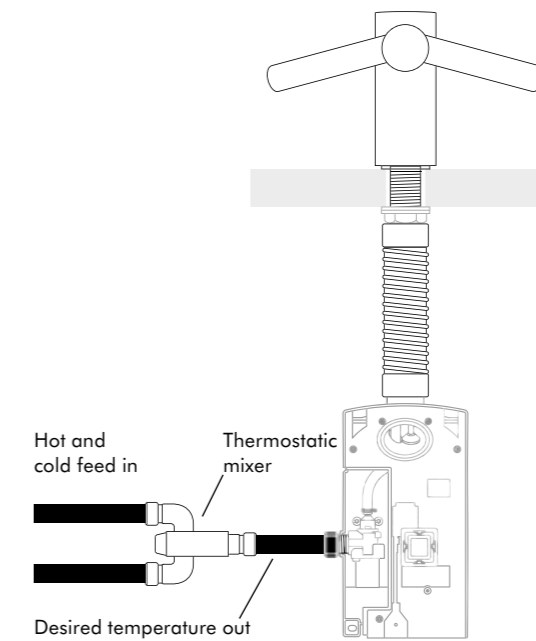

If connecting to cold only water feed, you will need to install a heater.

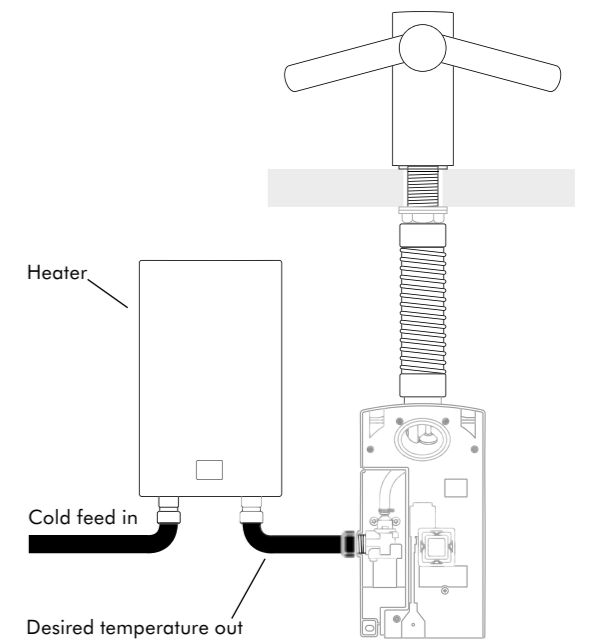

Installation overview

5

Fix cover and motor

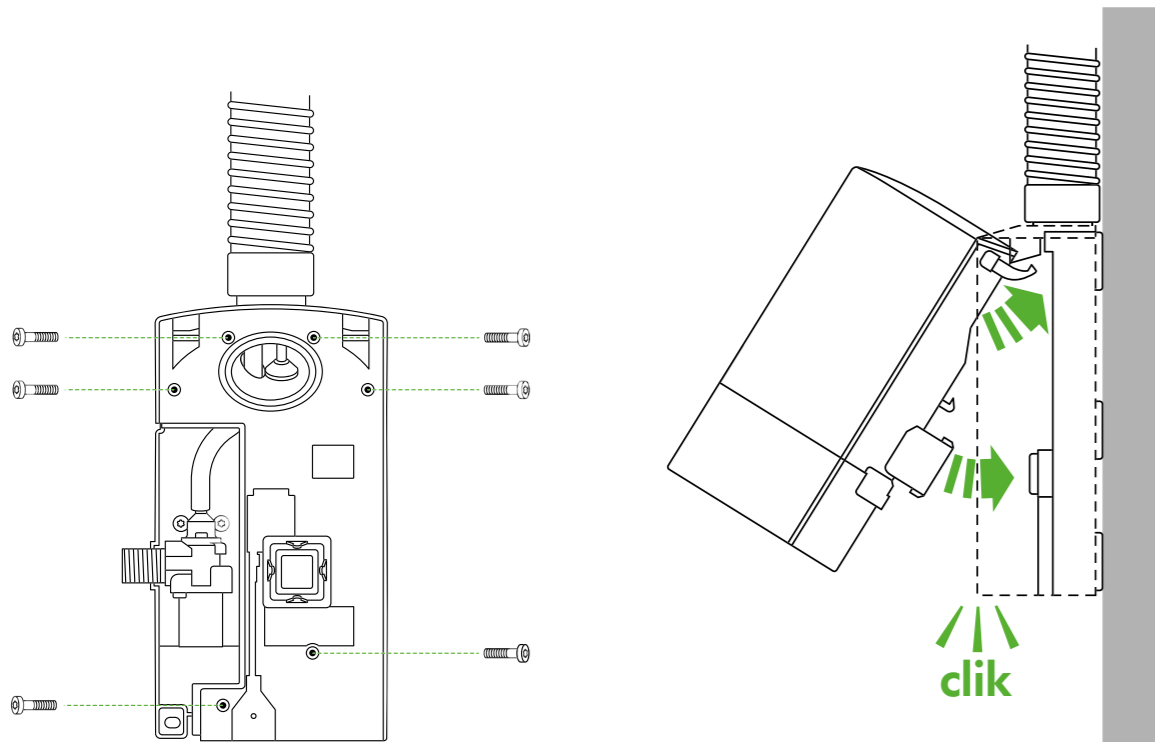

Installation overview

What's in the box

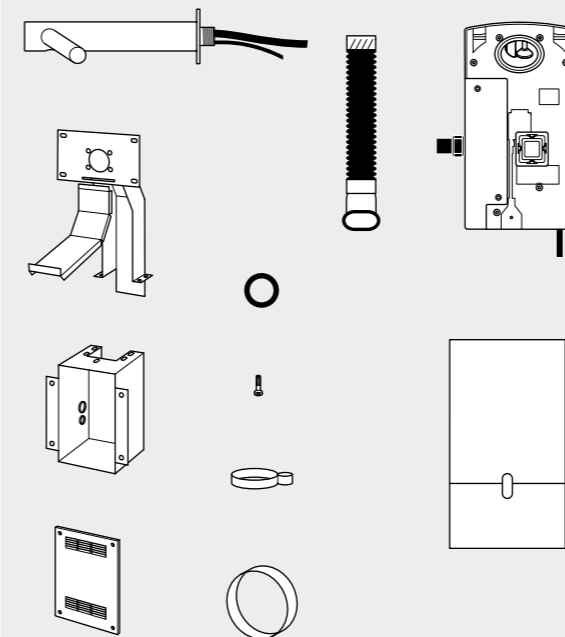

Additional items you will need for installation

- Torx T15 screw driver – long handle
- 37 mm Box spanner
- Mains power supply
- Water temperature control: Thermostatic mixer or heater
- Water pressure control if pressure is not between 1 and 8 bar

1

Install studwork and metal enclosure

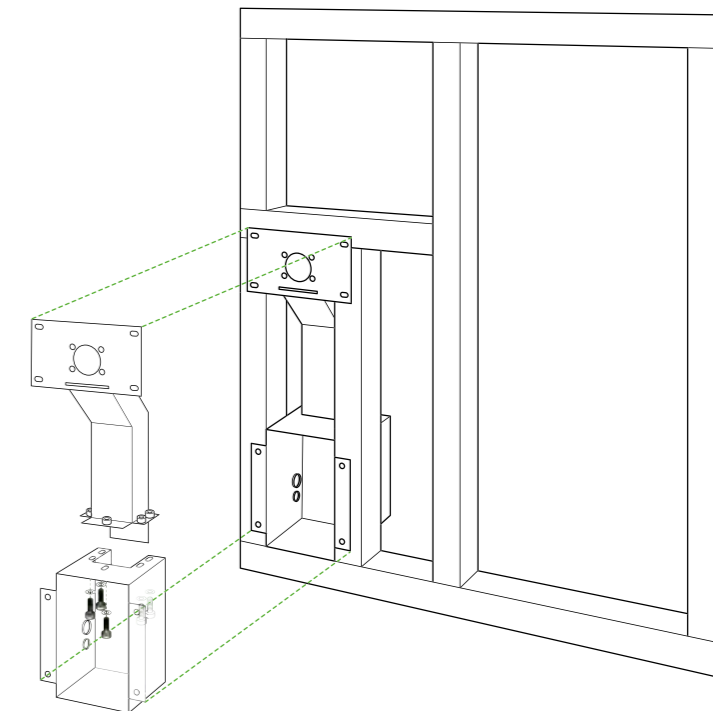

Installation overview

2

Install plasterboard

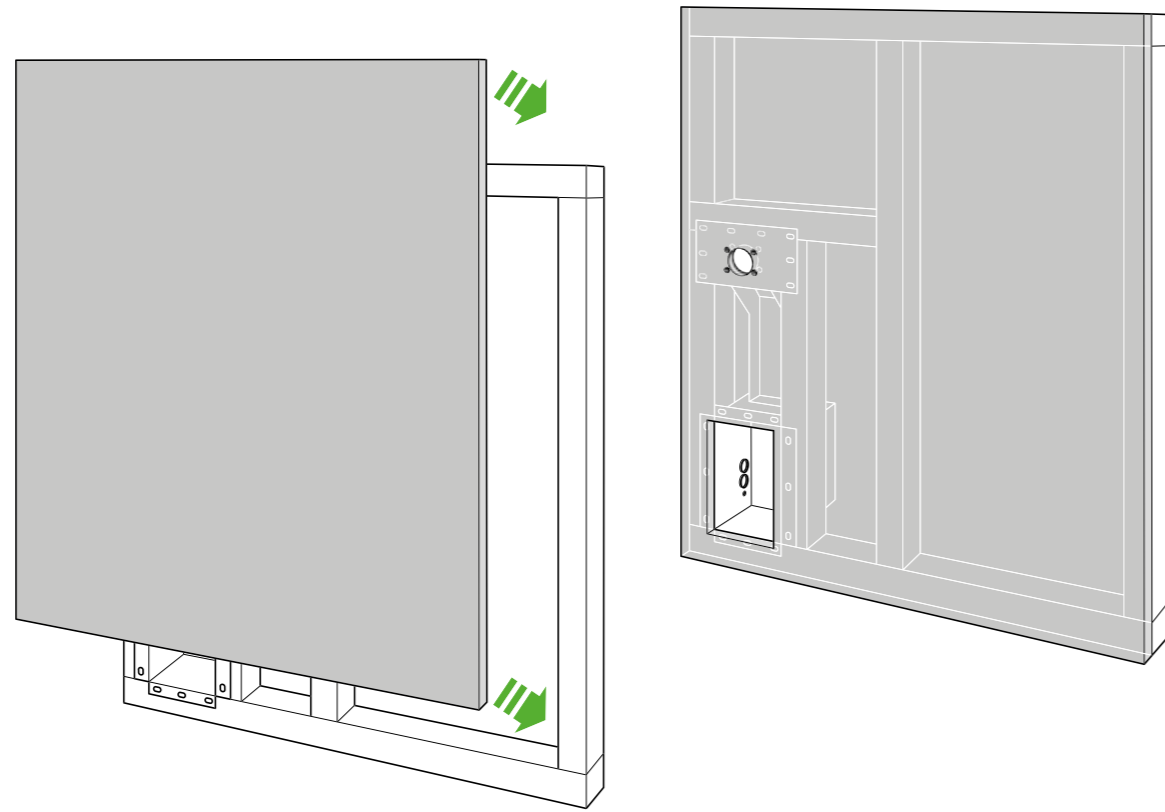

3

Install Dyson Airblade Tap hand dryer

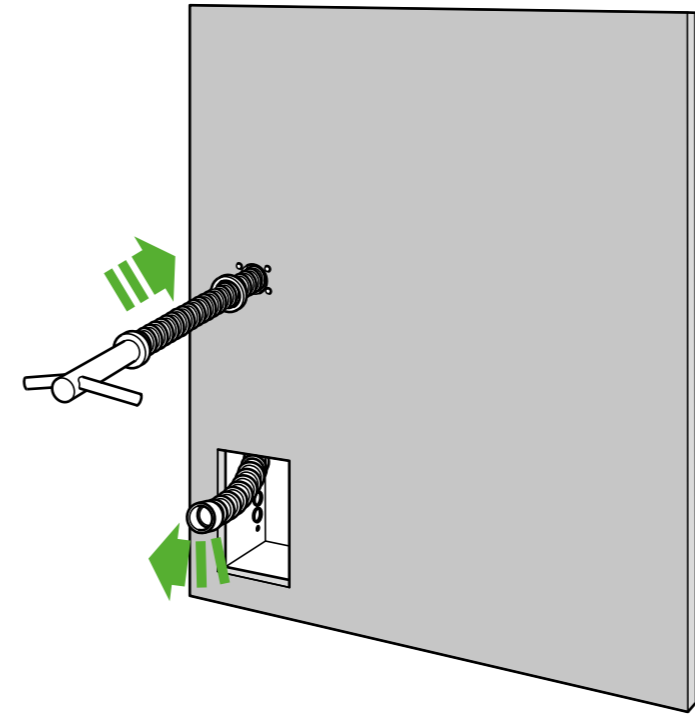

4

Detach and install base of motor bucket in metal enclosure

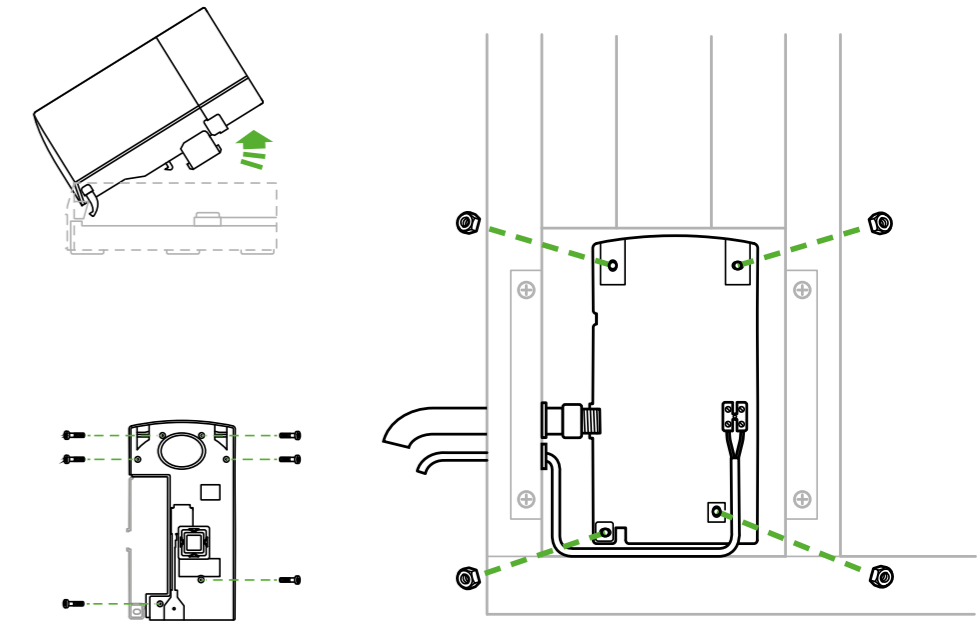

Installation overview

5

Connect supplies Electrics

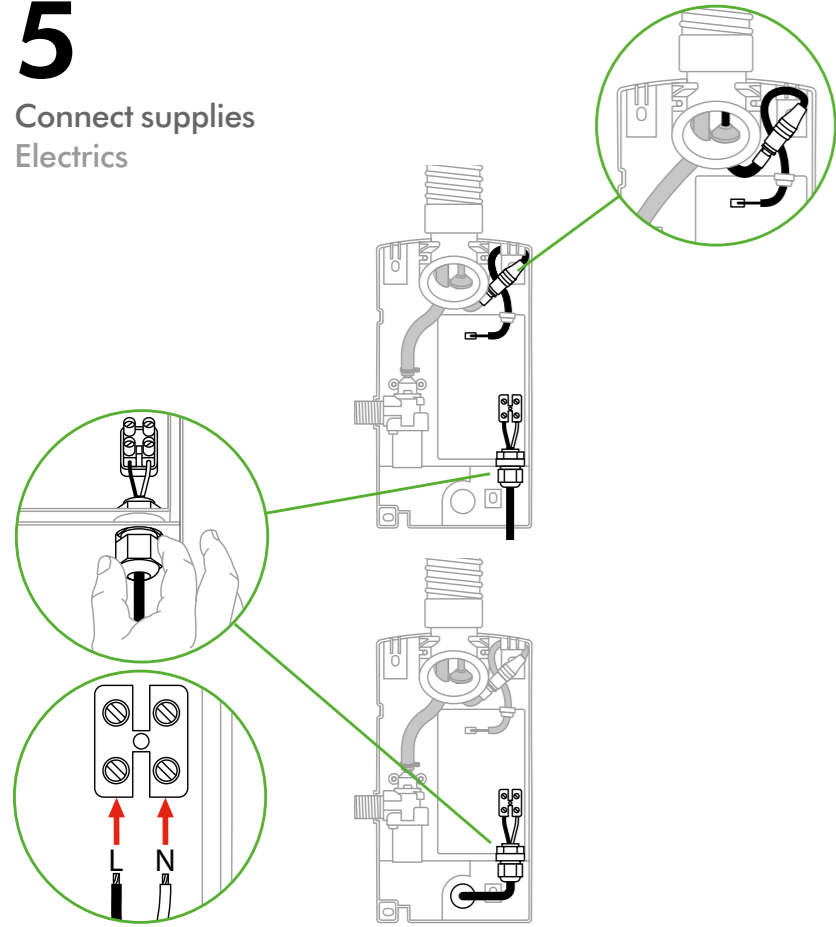

Connect supplies Water

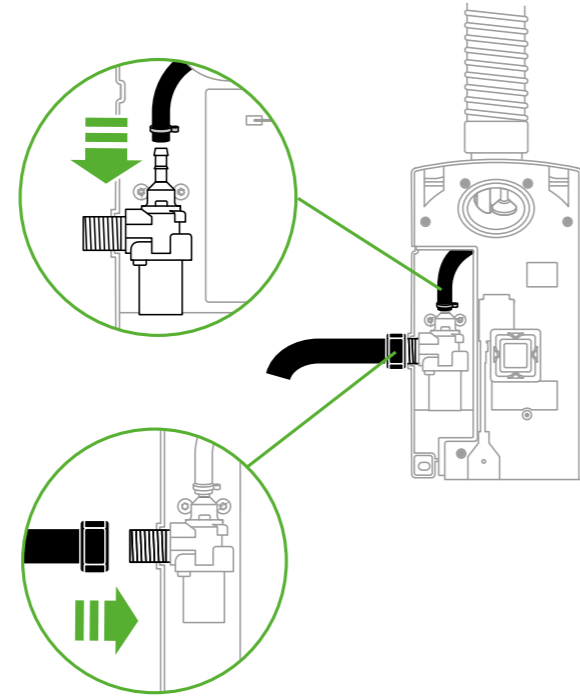

If you are connecting a hot and cold water feed, you will need to install a thermostatic mixer.

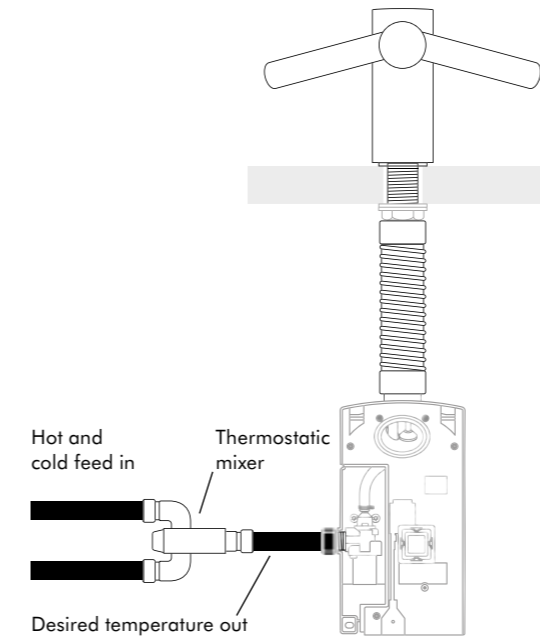

If connecting to cold only water feed, you will need to install a heater.

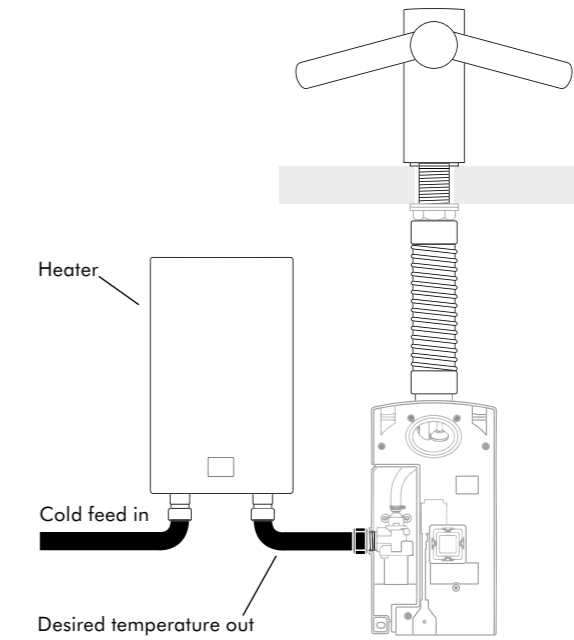



AB11
BMW, car dealership,
Belgium.

Post installation

- Cleaning guide.
- Instructional communications.
- The Dyson Airblade™ hand dryer range.

Dyson Airblade Tap hand dryer cleaning guide

The Dyson Airblade Tap hand dryer should be cleaned daily.

Follow these three simple steps to ensure the machine performs to its best and remains hygienic.

For a full version of the guide visit www.dysonairblade.co.uk

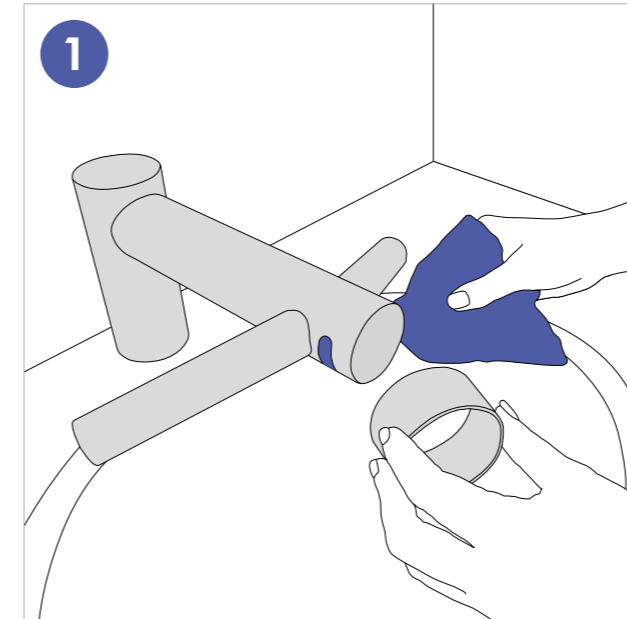

Wipe sensors using a soft cloth and non-abrasive cleaner then place cleaning cap over sensors to prevent activation.

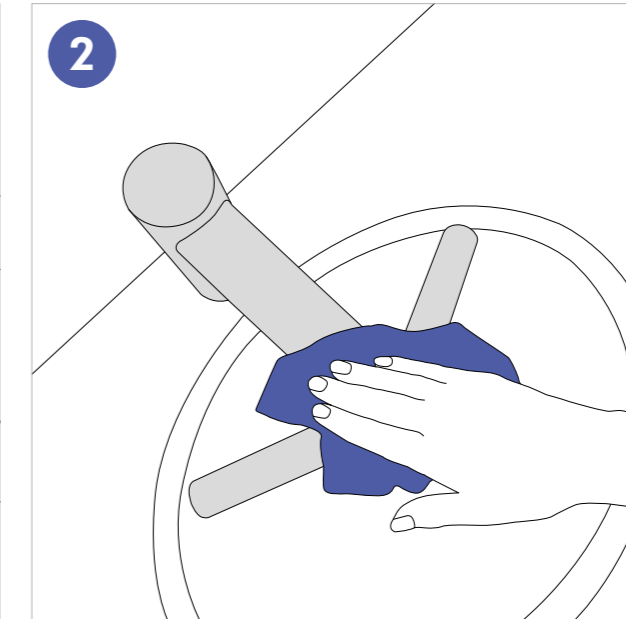

Clean all tap surfaces, sink, mirror and any walls or counter tops. When complete **REMEMBER** to remove cleaning cap.

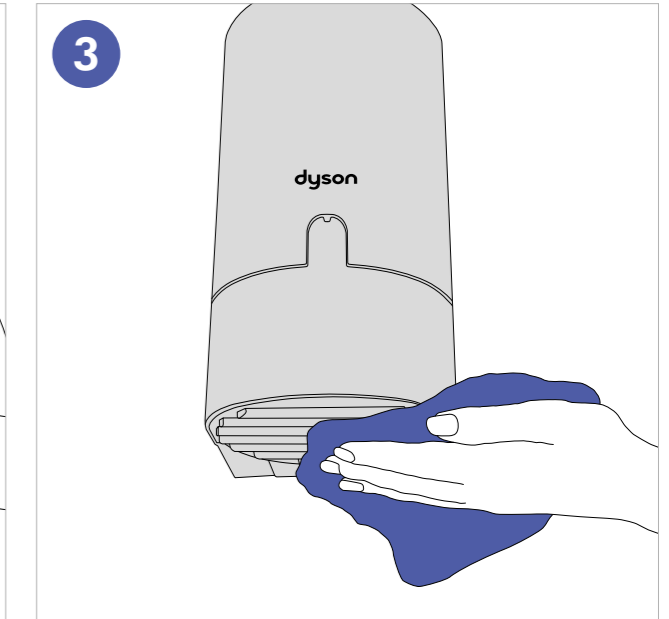

REGULARLY clean air inlets on base of motor bucket (under sink). Ensure plug hole in sink is free from blockages so water can drain freely.

Instructional communications

We have created specific washroom communications to enhance the user experience.

Back of cubicle door/urinal wall communications.
180 mm x 210 mm.



Dyson Airblade Tap hand dryer arm stickers
22 mm x 106 mm.

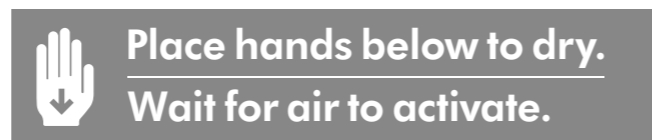
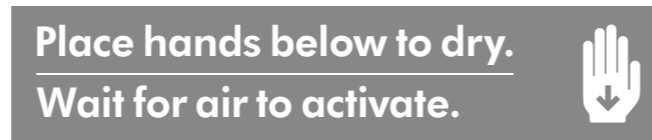

AB09
Business Design Centre,
exhibition centre,
London.



AB11
Kelloggs,
food production,
Holland.

The Dyson Airblade™ hand dryer range

AB
08



Sprayed nickel



White

AB
14



Grey



White

AB
09 Short



AB
10 Long



AB
11 Wall



dyson airblade tap

Contact us for more information
or to find out how to buy:

0800 345 7788

www.dysonairblade.co.uk

Architects can learn more
through a RIBA CPD.



The Carbon label is a trademark of the Carbon Trust.
The NSF logo is the registered trade mark of NSF International. HACCP International non-food certification mark is the registered trademark of HACCP International. HACCP International have certified Dyson products based on their recommended installation and operating conditions. Licensed by Dyson.

JN: 74971 26.05.15